

RAIL TUNNELS – LINEAR HEAT DETECTION USING FIBER OPTIC SENSING TECHNOLOGY

Bandweaver's FireLaser distributed temperature sensing (DTS) technology has a successful track record in providing fire safety and detection solutions as a linear heat detection system used within light and heavy rail infrastructure. Due to the specific need for a solution involving a low maintenance, low cost of ownership, high reliability and effective fire detection, FireLaser DTS technology is very well suited to the railway industry type applications. The areas where FireLaser has distinct advantages are in the areas of Tunnel monitoring and Station platform/concourse areas.

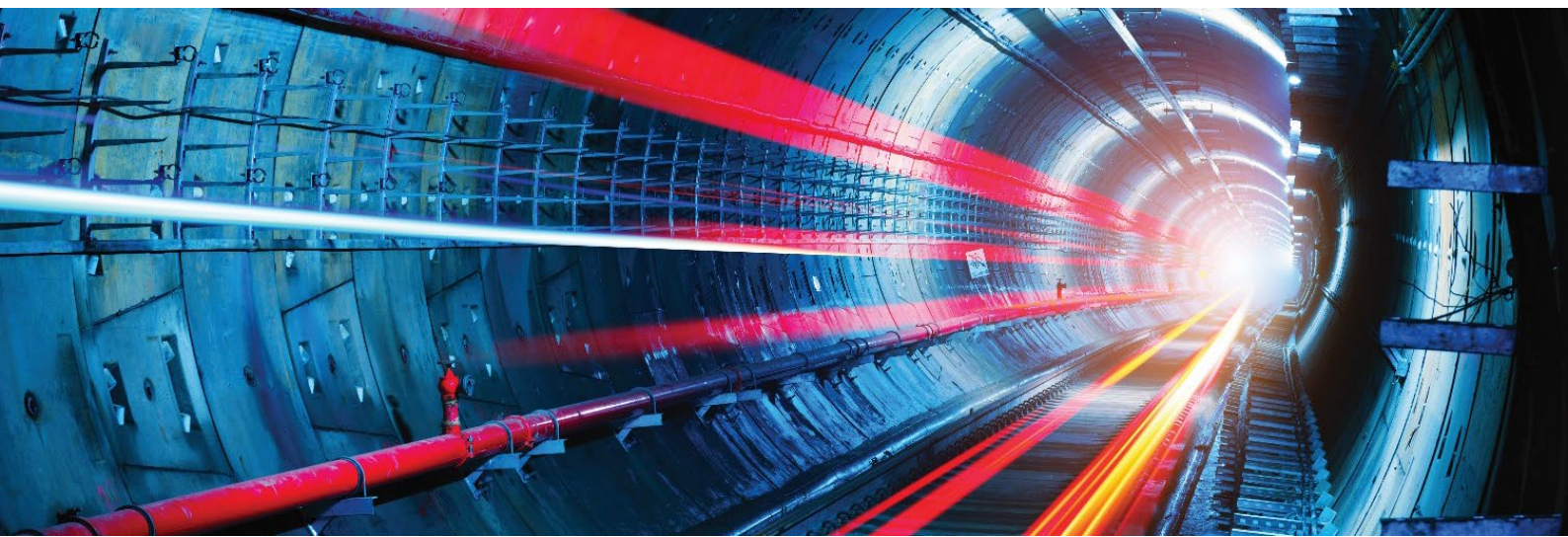

INTRODUCTION

It is fundamentally important that underground links have a high degree of reliability where the main risks are:-

- > Safety of passengers and staff.
- > To ensure continual availability of the tunnel and platform areas.
- > To ensure trouble free operation.
- > Minimize maintenance work.

Fires and field tests have shown that the temperature of burning materials in tunnels rises much more quickly than can be expected in a normal fire. How quickly and in which direction smoke and gases move depends on various factors, such as:-

- > The extent of the fire (fire load, intensity)
- > The ventilation system
- > Natural air currents
- > The smoke venting system
- > The profile and pitch of the tunnel

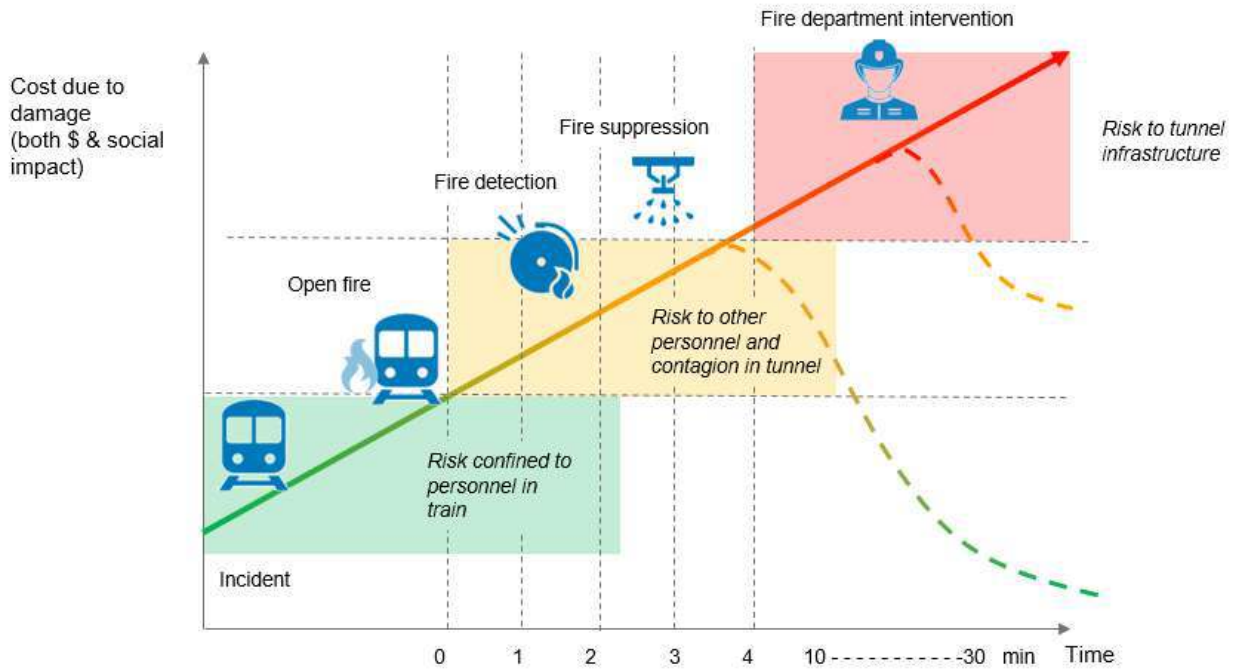

Figure 1 - Progression of tunnel fire with time

It is even more critical in tunnel situations for the system to detect early on to minimize damage. If action is taken early fire can be contained to a single location. However, if allowed to spread then there can be significant damage to infrastructure and risk to personnel.

SMART ALARMS & FULL COVERAGE

Two of the key advantages of fiber optic linear heat detection (LHD) systems are based on the smart alarming functionality and the distributed nature of the measurements. With fiber optic LHD systems based on DTS, three different types of alarms are configurable.

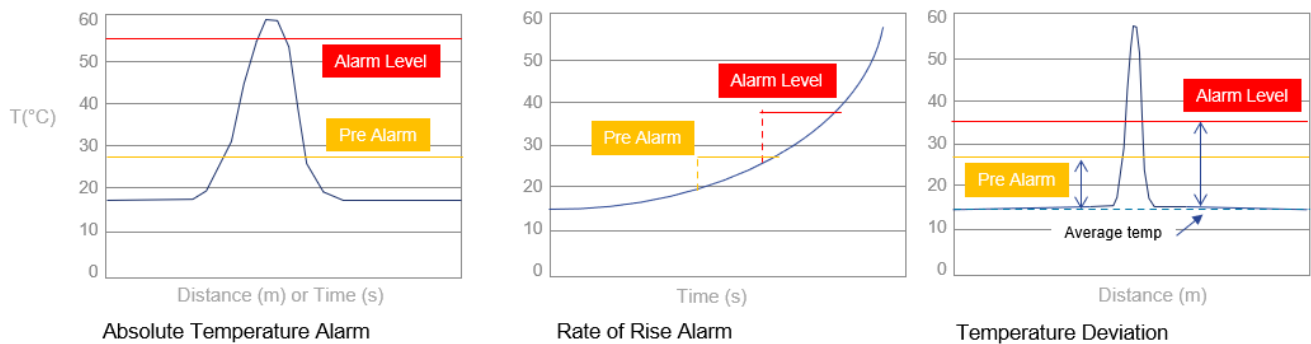

Figure 2 - Smart alarming with fiber optic linear heat detection systems



With regards to the distributed nature of the measurement, with LHD systems the system provides a full temperature profile with points every 0.5m along the length of the system. In traditional detection systems, if the seat of the fire does not happen to be immediately under a point type sensor, the fire can no longer be detected with certainty, mainly due to detector spacing.

The FireLaser fire detection system does not have any such "gaps", since the radiation heat given off by the fire is applied over the continuous length of sensing cable and is recorded and displayed accordingly.

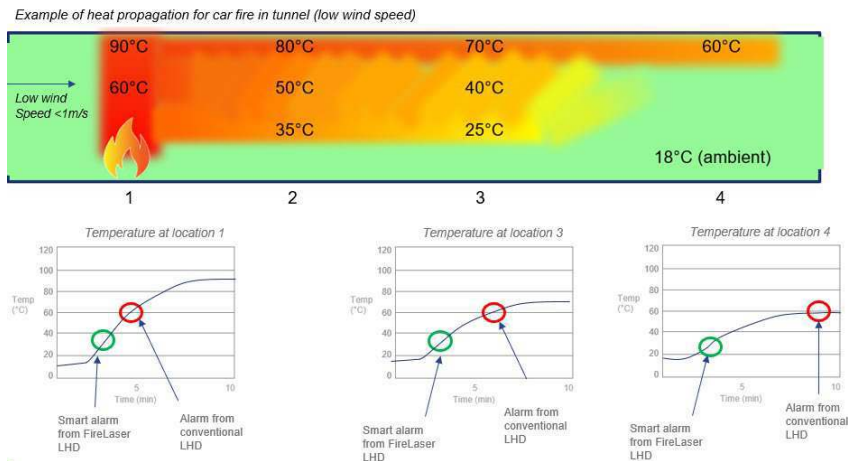

Figure 3 - Temperature profile of tunnel fire

The diagram above shows the typical heat profile of a tunnel fire in the surrounding area. With the combination of the distributed nature of the system and the smart alarms the system can detect early on and provide alarms even with wind speeds up to 10m/s.

SYSTEM INTEGRATION

The fire detection system which incorporates a FireLaser DTS system recognizes a fire and automatically actuates the relevant, preprogrammed protective measures (alarm signals, ventilation control, extinguishing measures, etc.). The fire alarm system needs to provide information on the exact location of the fire and key data on fire development in order to bring the necessary rescue or fire-fighting measures into action systematically.

The Bandweaver FireLaser DTS linear heat detection system has a centrally located sensor control unit, which is able to determine the temperature at any position along the length of connected sensor cable. The sensor cable is fed through the assets to be protected, which may include station platforms, escalators, ceiling and floor void spaces, switch rooms, as well as the tunnels used by the rolling stock. The cable is divided in software into multiple fire detection zones, where each zone can have its own unique characteristic alarm thresholds assigned to it, so the system is extremely flexible in this regard.

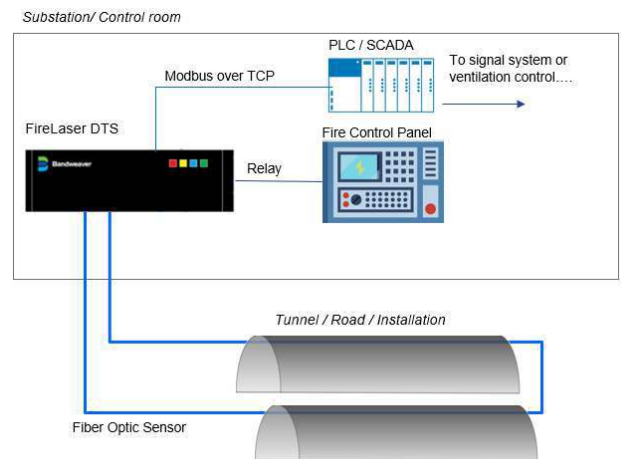

Figure 4 - Example of System Architecture

SMART ZONE CONFIGURATION

The FireLaser LHD system gives the unique capability to configure the smart alarms in conjunction with smart zones. This enables each zone to have its own specific configuration according to the specific environmental conditions or integration with other elements of the system. Examples where you may want different zone configurations include, emergency exits, tunnel ends, ventilation zones, fire suppression.

The following table gives an example of how the smart zones integrate with the rest of the system. Because the fiber optic LHD system gives you the precise location and temperature of each event you can decide how the system will respond. In some cases, an entire zone may communicate through a relay switch (e.g. direct contact to the fire panel) and activate the fire suppression for that zone. Or in other cases the actual data can be transmitted via Modbus (or other protocol) to the system where it can decide which actions to take. The diagram below details how this may work with integration of the other sub systems.

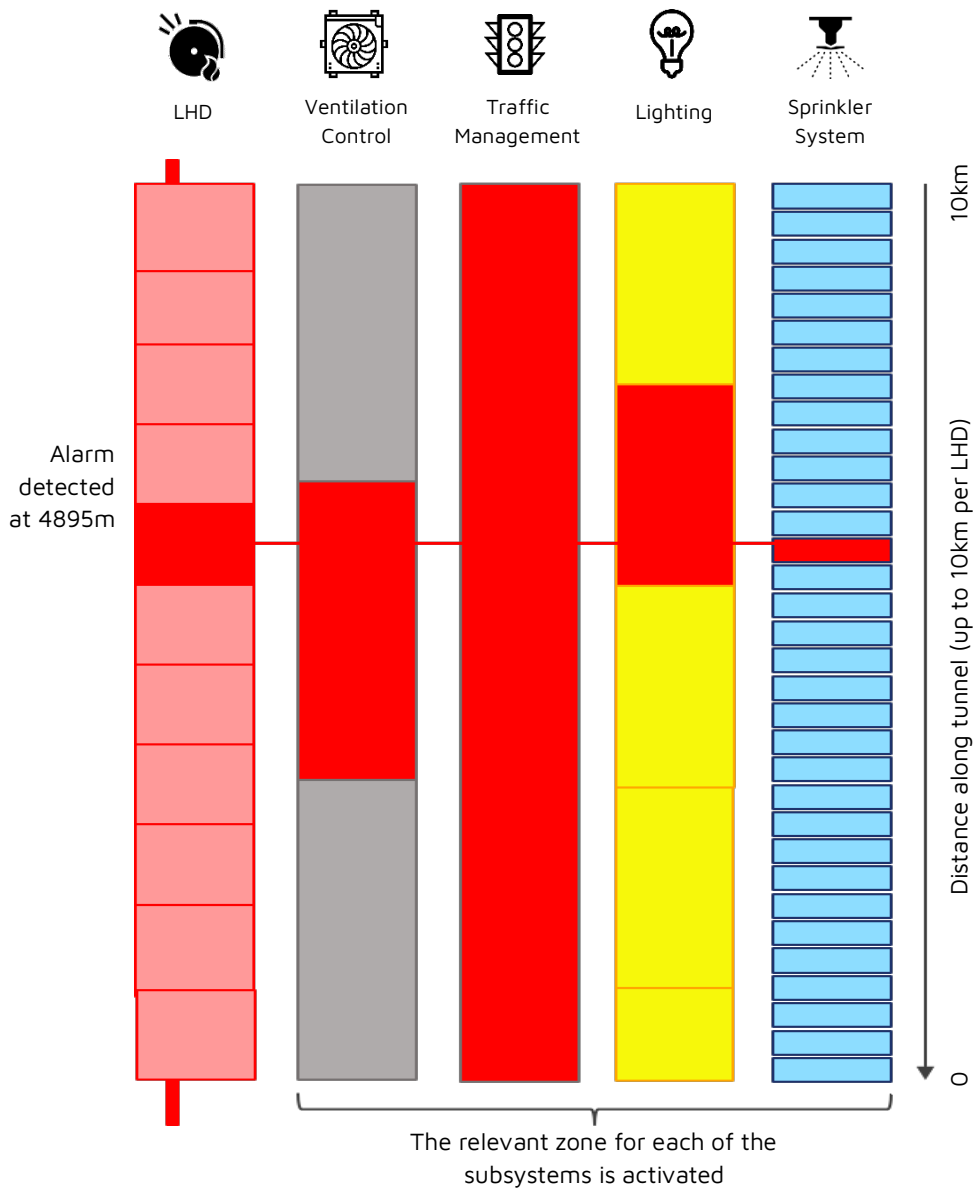

Figure 5 - Example of smart zone configuration



SENSING CABLE

The sensing cable is a completely passive element and is based on standard fiber optic telecommunications fiber. For the fire industry the standard fiber configuration has been using a 62.5/125 fiber optic due to its superior performance at distances up to 10km.

Because the sensing cable is made from fiber optic and is completely passive, it has the following benefits:

- > **Continuous coverage:** No discrete sensors but continuous spatial measurements. The FireLaser provides measurement points every 50cm
- > **Immune to electromagnetic interference:** Can be used in areas of high electromagnetic activity without fear of affecting or being affected by other electrical equipment
- > **Corrosion and vibration resistant:** As the sensing element has no moving parts and immune to corrosion, the cable has an extremely long lifetime and can be in excess of 30 years

The FireFiber range of cables are designed to give maximum protection to the fiber optic while maintaining a thermal conduction which can enable the system to react very quickly. It is also very lightweight and flexible, making it easy to install.

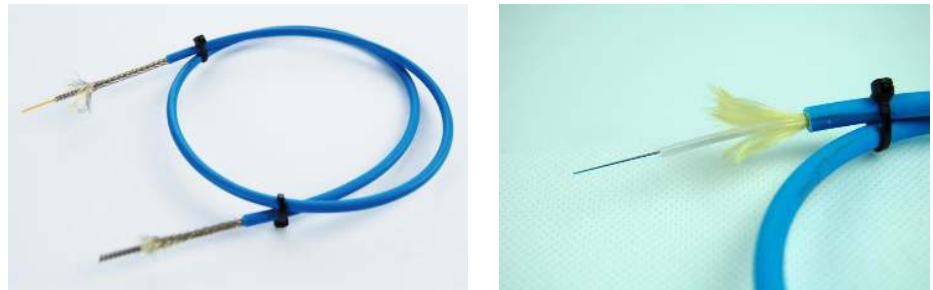

Figure 6- Examples of FireFiber cables

CABLE INSTALLATION AND POSITIONING

The sensing cable is suspended from a tunnel ceiling by use of various fixing methods. If the sensing cable is installed in a straight line (along the line of sight of the tunnel), fixings should be installed on the tunnel ceiling at the rated separation, dependent upon the method employed. If the cable is not installed in a straight line, additional fixings may be required. Cable ties should be used to attach the sensing cable to the fixings. It is important that the sensing cable is installed carefully so that the cable parameters are not exceeded. Depending on the tunnel size and dimensions one or two cables may be required.

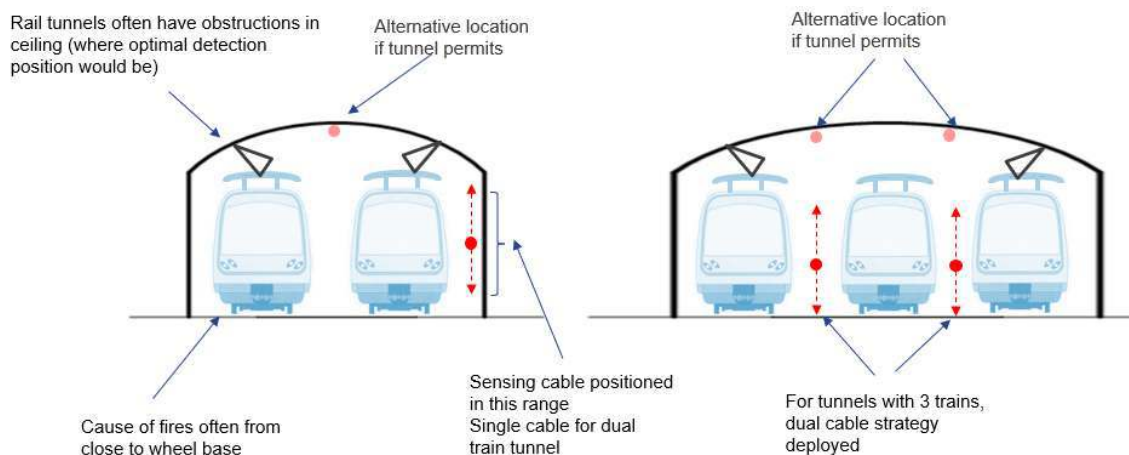

Figure 7 - Single and dual cable configurations





The minimum level of protection is achieved by locating the sensing cable at the tunnel ceiling, its position defined by the structure of the ceiling, but generally under a flat ceiling, the sensor cable can be located in the center of the ceiling, at a distance of 25mm to 150mm from the ceiling surface. A suitable cable fixing method should be adopted, using the recommended cable fixing distances, generally 1.5m apart. This type of application is a so called "room protection" (see approvals) application, where the sensor cable is located at a distance away from the main fire risk.

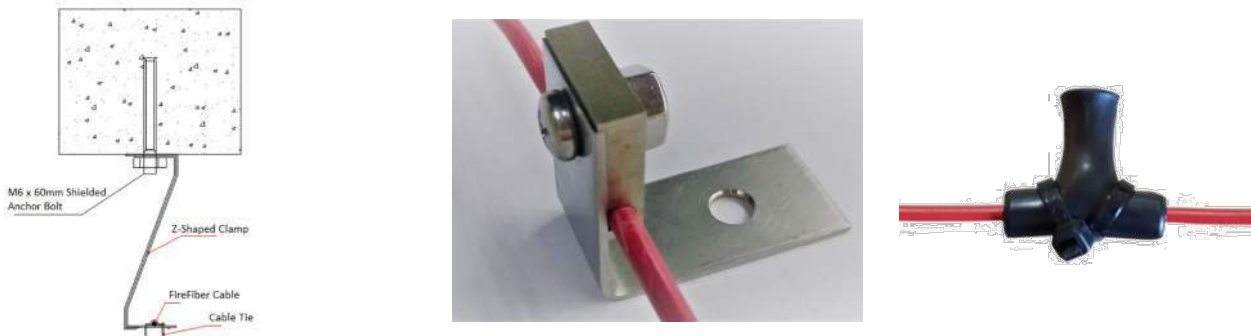

Figure 8 - Examples of cable fixtures

The location of the FireLaser controllers for an application is governed mainly by the geography of the site. Depending on the specific configuration the cable length per channel can be as much as 10km. this implies that accurate cable length calculations need to be made during the design process. A reasonable allowance for error should be made by the system designer. Many new installations will tend to use twin bore tunnels, for rail or road traffic to travel in opposing directions. Fiber optic cable is installed in each leg of the tunnel provided there is access from one tunnel to the other, so that cable can conveniently form a loop.

SYSTEM REDUNDANCY

Depending on the customer requirements, different levels of redundancy can be required. Essentially there are two key types of redundancy:

- **Cable Redundancy:** In the event of a cut to the cable, the system can continue to function (although a system alarm will be generated so that action for repair, analysis can be taken)
- **Controller Redundancy:** In the event of a failure to one of the fiber optic LHD controllers, the system will continue to function

Given that there are single tunnel, dual tunnel and multi tunnel configurations as well as single ended and loop configurations, there are a number of permutations. Below are some examples of some of the different arrangements.

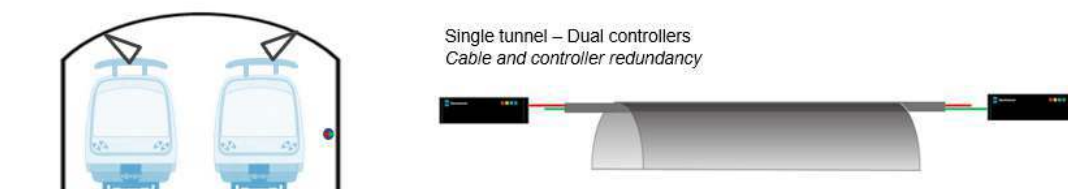

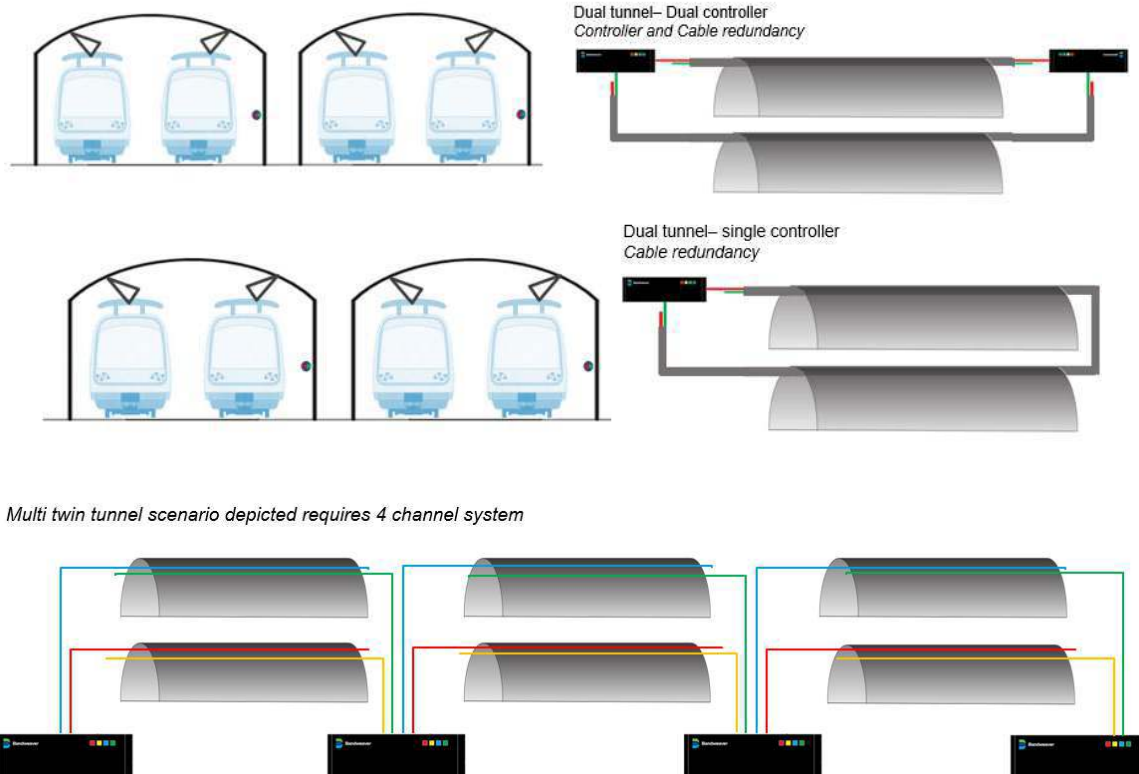

Figure 9 - System redundancy options

ABOUT BANDWEAVER TECHNOLOGIES

Bandweaver has been providing advanced fiber optic monitoring sensors and integrated technologies since 2002. With an installed base of over 60,000km and 8,000 systems installed, our knowledge regarding the application of distributed temperature sensing technology and linear heat detection within the fire industry is second to none. We focus on the safe integration of FireLaser DTS technologies into clients' proprietary systems and Bandweaver and our partners provide exceptional systems design support, product support during installation and provide long term maintenance packages.

For further information please contact our global team at info@bandweaver.com

