

FenceSentry Perimeter Intrusion Detection System Gas Pipeline Substation Protection



The Scenario

The operator PetroChina is constructing the mid-section of the natural gas pipeline of the Third West-East Gas Pipeline with a total length of 2090 kilometres. It starts at Zhongwei and passes through 7 provinces Ji'an. The pipeline design pressure is 10 MPa, the designed annual gas transmission capacity is 25 billion cubic meters, and the pipe diameter is 1219 mm.

The project is utilising the latest technology including automated and remote operations and decision making. A total of 5 management offices, 33 substations (with 10 compressor stations) are all included in the scope of work. All with differing security requirements and all require state-of-the-art security, often in remote locations.

For the PIDS element, the customer wanted to employ a system that can precisely locate the intrusion event.

Client Requirements

The project included new build along the pipeline and the associated substations and upgrade to existing technology and security systems. All information needed to be incorporated within both SCADA infrastructure and PSIM security management system. The customer was evaluating several technologies across the sites, including:

- CCTV with advanced Video analytics
- Beam detectors
- Fiber optic PIDS system

The fiber optic PIDS system will be fence mounted with separate sensors covering the gates.

In terms of visualisation and management, the client required a central system at headquarters with GIS (Geographic Information System) information for all the sites with a map view detailing the alarm events.

What Did We Do?

Bandweaver worked with the customer to design a plan to address which systems required fiber optic PIDS and how to integrate with the other elements of the security system. Because the customer wanted precise location of the intrusion event. It was decided to deploy the Bandweaver FenceSentry which detects intrusion events with a precision of 1m. After carrying a threat analysis with the customer on all the sites, it was decided to deploy FenceSentry across 26 of the sites.



Figure 1 - Zhongwei Compressor Station

Because there was a wide variety of fence types across the different sites, different cable types and configurations were deployed. Below is an example of a serpentine configuration on the fencing in the station yard.

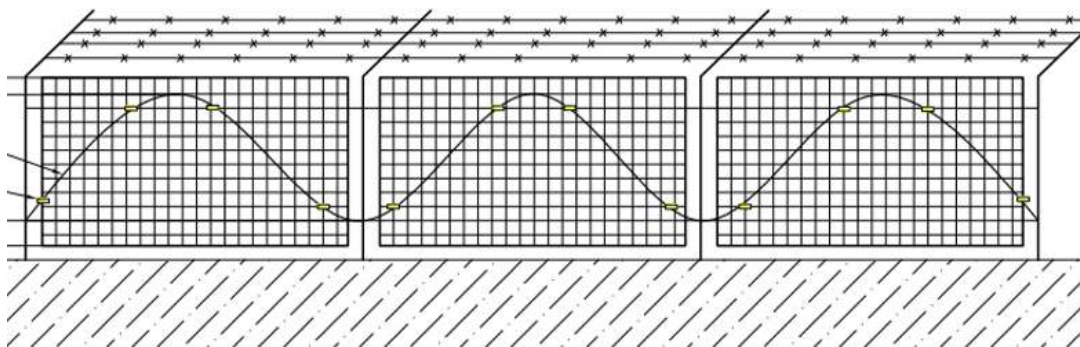

Figure 2 - Cable configuration on station yard mesh fence

On other sections, the wall was of a concrete/brick construction with a mesh/wire topper. In this scenario the sensing cable was mounted on the topper section. Bandweaver designed all the interfaces to ensure there is complete coverage, protection of the cable and maintenance loops where appropriate.

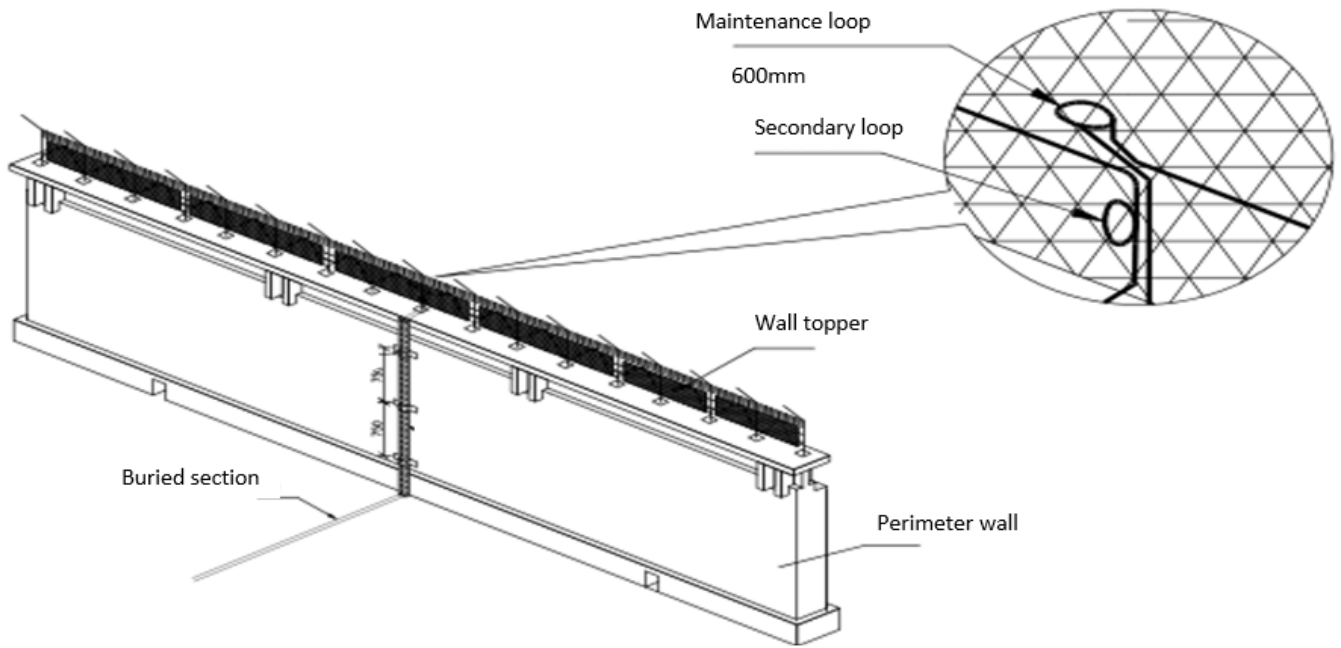

Figure 3 - Schematic of cable installation and interface at the wall



Figure 4 - Photo of cable mounted on fence topper section in serpentine formation



Figure 5 - Phot of cable mounted on fence topper section on top wire



Figure 6 - Cable configuration at gate

At all sites, the FenceSentry was installed in a 19" rack in the control room. It was connected to the network and interfaced with both the PSIM and the SCADA system.



Figure 7 - FenceSentry installed in control room



Benefits to the Client

When evaluating the PIDS system, the client used several factors to make the choice across the lifetime of the project. Below are the benefits which helped persuade the client that fiber optic PIDS systems offered multiple benefits over other technologies:

- **Low Cost of Ownership:** Because the fiber is the sensor the operator does not have the concern of whether to position the sensors as there is complete coverage. This leads to lower design and installation costs. There is also no in-field power or communications cable requirement which means both lower capital costs and lower ongoing operations and maintenance costs.
- **High Reliability:** Another benefit of the passive, inert nature of fiber optics is that they are very reliable and so there is no downtime. They are completely passive and are immune to EMC interference, not affected by dust or other environmental factors and are completely non-corrosive. Therefore, the lifetime of fiber optic cable can be greater than 30 years, without any maintenance required. Addition to the lower maintenance costs, they also provide a higher level of coverage which lowers the overall risk and improves protection levels.
- **Robust measurement:** With the 2-channel loop, *cut-redundancy* configuration the system continues to operate seamlessly even in the event of a cut to the cable (whether intentional or accidental) thus providing an extremely physically robust system. Also, with the software configurable *smart zones* and advanced environmental algorithms this leads to lower nuisance alerts and greater confidence in the system.
- **Precision of Detection:** The FenceSentry PIDS system can locate an intrusion event to within 1m which means that events can be located extremely accurately, and early action can be taken to prevent any escalation of any intrusion incidents. With the integration with the CCTV a secondary form of verification can be employed to further clarify and improve decision making.
- **Intrinsically safe:** The optical power within the sensing cable is too low to be able to cause ignition and so is fully certified and suitable for use in hazardous areas where explosion or combustion of materials is a real risk.

About Bandweaver Technologies

With an installed base of over 60,000km and 7,500 systems installed worldwide, Bandweaver's vision is to be the first choice for integrated distributed fiber optic sensing solutions across the globe. Since 2002, Bandweaver has been committed to delivering reliable, innovative, client-centric, and value-added products and services, via a dedicated and talented team of people.

Bandweaver manufactures and distributes advanced fiber optic monitoring sensors and integrated technologies, enabling customers to monitor, secure and keep personnel and critical assets safe.

With quality and excellence as fundamental elements of Bandweaver's portfolio, the business is continuously developing its range of technologies, including Distributed Temperature Sensors (DTS), Distributed Acoustic Sensors (DAS) and integrated smart intelligent software solutions.

Utilising the latest technologies, Bandweaver provides solutions for Security, Fire, Power, and Pipelines. For further information please contact our global team at info@bandweaver.com

